



HIPOWER PARALLEL SYSTEM
A Revolution in the Power Generation Industry

**PARALLEL
SYSTEM**



HIPOWER™
your partner for power

New solutions for parallel systems

All-new HIPOWER parallel device:

- Multiple gensets paralleling in three different voltages (120/240 1Ph, 120/208V 3Ph or 277/480V 3ph) achieved through the voltage selector switch.
- Parallel with utility.
- Load sharing and kW control.
- Load sharing and kVAR control.



The control panel is configurable via its front panel or via a PC without dedicated software. It has an embedded web site which is password protected.

The control panel has an analogue load sharing line so as to be compatible with all types of analogue load sharers.

Thanks to its Super Droop feature, the HIPOWER genset does not need extra communication ports for load sharing. The units only communicate via the busbar.

In SUPER DROOP mode, the load sharing is managed between 60.50Hz (0% load) and 60.00Hz (100% load). This is adjustable.

For this specific droop, it is not necessary to set the engine speed precisely, and no connections are required between each unit, not even the 0V.

- The kW and kVAr load sharing is managed with super droop.
- The unit includes the usual protections (phase sequence protection included).



PERFECT FOR MOBILE OR REMOTE GENSET APPLICATIONS

HIPOWER MAKES GENSET PARALLELING SO SIMPLE. THE DIGITAL SUPER DROOP FEATURE (WIRELESS LOAD SHARING) MAKES IT SIMPLER. THIS IS WHY CABLING BETWEEN UNITS BECOMES USELESS.

UNIQUE TO THE MARKET

NO COMMUNICATION BETWEEN UNITS IS NEEDED TO ACHIEVE PARALLELING. THE CURVE IS ALMOST ISOCHRONOUS AT $\pm 0,25\text{HZ}$.



All-in-one genset control and paralleling unit

- Compact «All-in-one» module.
- 5 isolated serial ports: USB, RS485, 2 CANbus, Ethernet.
- SD card reader.
- I/O flexibility.
- New multi-function on graphic display.
- Internal, programmable by equations logic sequence.
- Internet interface.
- Fully compatible with all speed governors and AVR's.
- Full J1939 compatibility.
- 3 phase automatic utility failure sensing.

APPLICATIONS

- 2 to 14 gensets in parallel and change over with utility.
- 2 to 14 gensets in parallel and paralleled with utility for load transfer. (In this case, another control panel option is used for utility paralleling via CANbus).
- Static paralleling (engine stopped).

ISOLATED INTER-UNIT CANBUS

The control panel has an isolated inter-unit CANbus port for information transfer (dead busbar management, static paralleling, KW and KVAR load sharing...). The inter-unit bus allows more information exchanges between modules and reduces the wiring and the number of I/O used on each module.

It also allows tiebreakers management.

PROGRAMMING BY EQUATIONS

The controller is a real PLC unit where equations and sequences can be programmed directly by the user without any additional software tool. The programming is written with basic text editor software.

INPUTS / OUTPUTS

An extensive number of input/outputs can be added.

Extension modules (DIN rail mounted) can be added on the CANbus available ports increasing the total amount of inputs/outputs up to 128 digital inputs, 64 digital outputs, 44 analogue inputs and 8 analogue outputs.

MINIMUM OPTIONS

This compact controller is offered with

a minimum of options to fit all types of application without expensive add-on packages.

For specific needs, the control panel can include the following options:

- Utility paralleling (Option available only with password).
- Phase shift compensation (i.e.: DYN11). (Only available with password). (This option is used when working with high voltage transformers and we want to correct the mismatch angle of the transformer for proper voltage measurement.)
- IEC 1131 programming (future enhanced).
- Super-droop (only active with key).



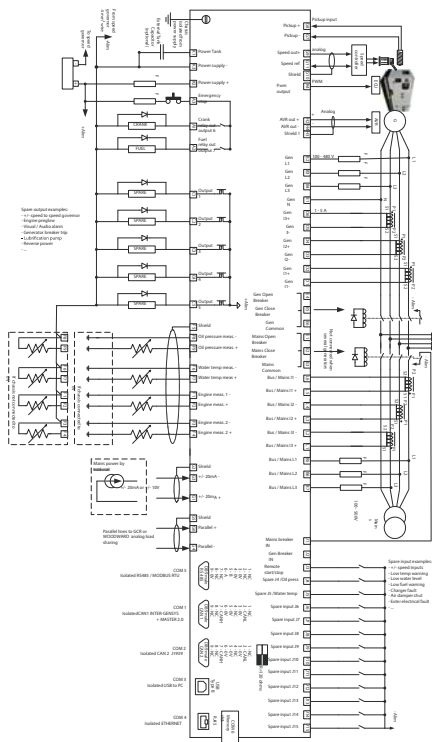

When several generators are paralleled with the utility another control panel (MASTER) is required.

CANbus connection via inter-module for:

- Paralleled gensets with multiple utility connections.
- Electrical protection for genset and utility.
- Electrical parameters display for genset and utility.
- Automatic paralleling with utility (frequency, phase and voltage).
- Power factor control when paralleling with utility.
- KW power management with several modes:
- No break change over with load transfer.
- Permanent paralleling in base load.
- Permanent paralleling in peak shaving.
- Import / Export mode. Parallel between multiple generators and utilities.
- Utility paralleling and peak shaving capabilities are optional.

Functions

Control & Management

- Manual & automatic engine control.
- Automatic start/stop control depending on load demand.
- Dead busbar management.
- Isochronous or droop kW load sharing control (via CANbus serial port, up to 14 generators)
- Constant voltage (or droop) kVAR load sharing control (via CANbus serial port, up to 16 generators)
- Power factor control when paralleling with utility.
- kW control (base load or peak shaving) when paralleling with utility.
- Protections
- Generator electrical protections: <F, >F, <U, >U, >I, >In, >P, <P, <-P, >Q, <Q, <-Q
- Utility electrical protections (option): <F, >F, <U, >U, >P, <P, <-P, >Q, <Q, <-Q, phase shift, df/dt.
- Short circuit protection.
- Phase sequence protection, phase shift compensation.

Synchronization

- Automatic frequency & phase synchronization (differential frequency meter + synchroscope available on screen).
- Automatic voltage synchronization (differential voltmeter available on screen).

Information display

- Engine parameters display: oil pressure, water temp, speed, hours run meter....
- Generator electrical parameters display:
- Phase-phase Voltage (3 phase RMS).
- Phase-neutral Voltage (3 phase RMS).
- Current (3 phase RMS).
- Frequency.
- Active power (3 phase + total).
- Reactive power (3 phase + total).
- Power factor (3 phase + total).
- Active power energy (kWh).
- Reactive power energy (kVARh).

Utility electrical parameters display:

- Phase-phase Voltage (3 phase RMS).
- Current (3 phase).
- Frequency.
- Active power.
- Reactive power.
- Power factor.
- Import active power energy (kWh).
- Import reactive power energy (kARh).

Alarms & events

- The last 50 alarms and last 50 shutdowns are recorded on non volatile memory.
- Data logging every 100ms.
- Other
- Electronic droop function (droop<1%). Allows load sharing without inter-unit communication. Quasisynchronous@ load sharing.
- "Watchdog" digital output for microprocessor life signal.
- Front panel: IP54 protection. Back panel: IP20 protection.
- CANbus for J1939 –male Sub-D9 pins - 120 ohm resistors selected by micro-switch.
- Ethernet I/O (remote communication – PC communication): for any requirements, please contact Hipower sales team.
- SD card reader.
- Languages: English, Spanish, French, German.

Features

Voltages, currents & frequency

- DC voltage power supply input: 8 to 35VDC, 600mA at 12VDC & 300mA at 24VDC.
- AC voltage inputs: 100 to 480Vac, 100mA max. Neutral terminal does not need to be connected.
- AC current inputs: 0 to 5A, 1VA. Each phase is isolated from the others.
- AC current overload: 15A during 10s.
- Frequency measurement: 45 to 70 Hz –

15VAC minimum between phase and neutral.

- Voltage control signal: The voltage control (AVR) is made either by a +/-10VDC output with adjustable span and off set or by voltage+/-voltage-contacts.

Environment

- Operating temperature: -20 to +70°C
- Storage temperature: -30 to +70°C
- Humidity: 5 to 95%. Tropic-proof circuits for normal operation in humid conditions.
- Altitude: 2000m

Inputs, outputs

- Digital inputs: NO or NC to ground.
- Emergency stop input: Norm. Closed 24V.
- Relay outputs (crank & fuel): 16A. The 24V is provided through the emergency push butt on.
- Relay outputs (breakers): 5A, 230VAC max. NO + NC available.
- Transistor outputs: 350mA, over current protected.
- Analogue inputs (oil pressure & water temp): 0 to 400 Ohms. Calibration is configurable.
- Analogue inputs (spare 1 & spare 2): 0 to 10KOhms.
- Calibration for speed and frequency control is made either by a +/-10VDC output with adjustable span and off set or by speed+/-speed- contacts.
- Magnetic pick up input: 100 to 10.000Hz, 2VAC minimum.
- PWM output for CAT and Perkins engines Ports
- 5 serial ports are available.
- USB and Ethernet for PC connection
- RS485 for Modbus RTU (read and write) – male Sub-D 9 pins – 120 ohm resistors selected by micro switch.
- CANbus for inter-Controller Panel connection – male Sub-D 9 pins – 120 ohm resistors by selected by micro switch.



HIMOINSA POWER SYSTEMS, INC.
 16210 West 110th Street
 Lenexa, KS 66219-1312

Tel: 913-495-5557
 Fax: 913-495-5575

www.hipowersystems.com

Call us (toll free) at: 1 866 710-2988



HIPOWER Generating sets
 engineered and design by HIMOINSA.
 Generator for home use, construction, industrial,
 rental, event, prime and standby power.

HIMOINSA[®]
 CORPORATION