



Proven Off-Highway Performance

.....

Your equipment deserves nothing less.

Funk drivetrain components are backed by 50 years of OEM and off-highway experience. This tradition of quality engineering and manufacturing goes into each planetary gear drive we produce.

When you choose a Funk planetary drive, you know you are getting the best combination of product design, manufacturing quality, application engineering support, and dedicated service.

To see how Funk drivetrain components can add value to your equipment, call 1-800-533-6446.

Full Line of Planetary Gear Drives

Funk Drivetrain Components

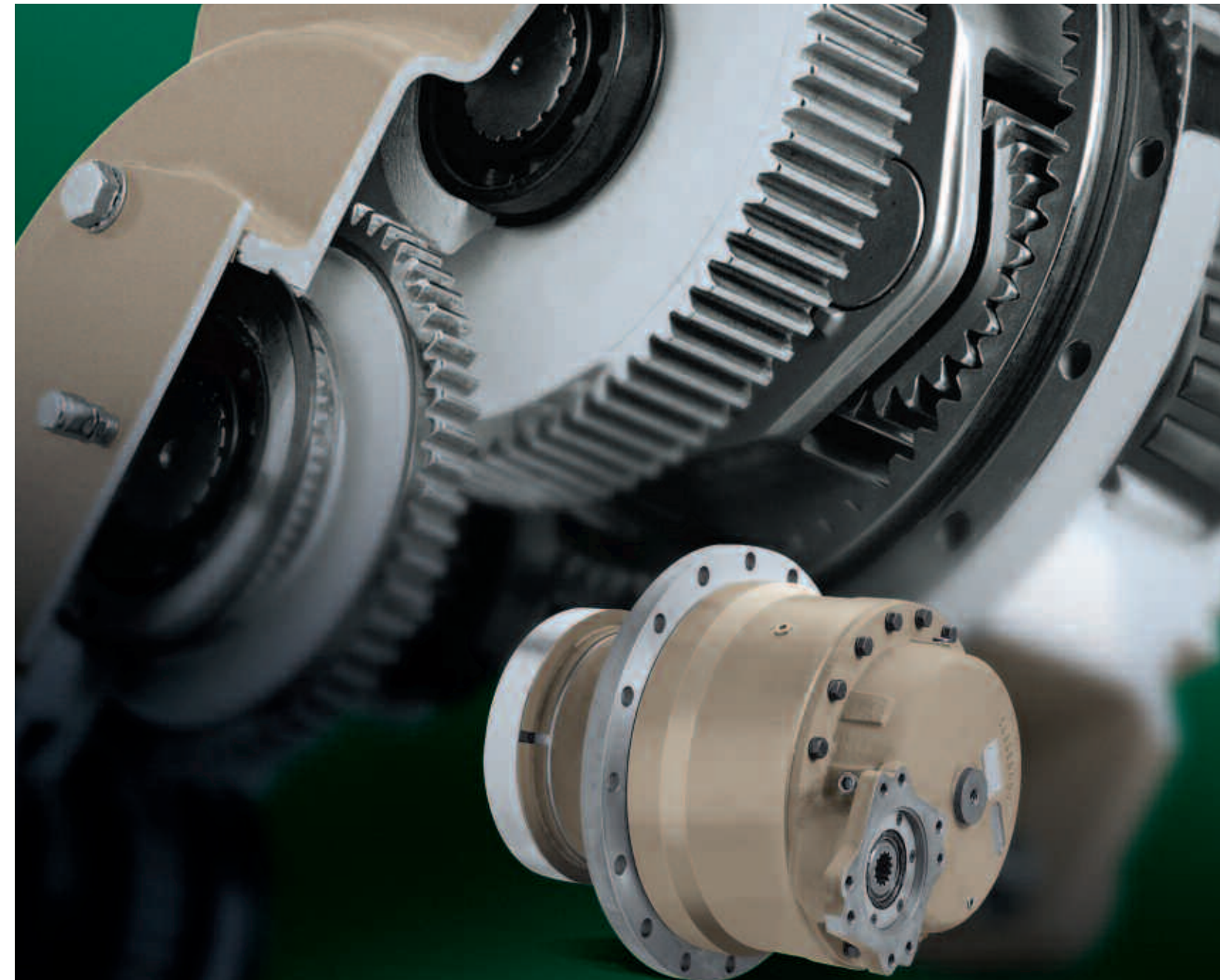

SEVEN DEPENDABLE MODELS.

.....

For additional information, contact:

John Deere Power Systems
3801 West Ridgeway Avenue
P.O. Box 5100
Waterloo, Iowa 50704-5100
Phone: +1 800 533 6446
Fax: +1 319 292 5075
e-mail: jdpower@JohnDeere.com

John Deere Power Systems
Doornelei, 24
2018 Antwerpen
Belgium
Phone: +32 3 238 89 69
Fax: +32 3 248 54 98



www.JohnDeere.com/jdpower

DKD1503 Litho in U.S.A. (06-06)

Your Source For Flexible And Reliable Planetary Drives

Seven models. Three types. Multiple gear ratios.

We offer a complete line of Funk planetary gear drives for OEMs in the ag, construction, manufacturing, marine, mining, and petroleum industries.

Typical applications for these durable drives include conveyers, cranes, crawlers, excavators, road rollers, track vehicles, winches, and many others.

Seven dependable models offered through three types — speed reducer, swing drive, and track drive.

**Maximum input power:
Up to 168 kW (225 hp)**

**Output torque intermittent:
Up to 162,696 Nm (120,000 lb-ft)**

**Output torque continuous:
Up to 88,127 Nm (65,000 lb-ft)**

**Ratio range: Starting at
3.27 to 117:1, Up to 64 to 194:1**

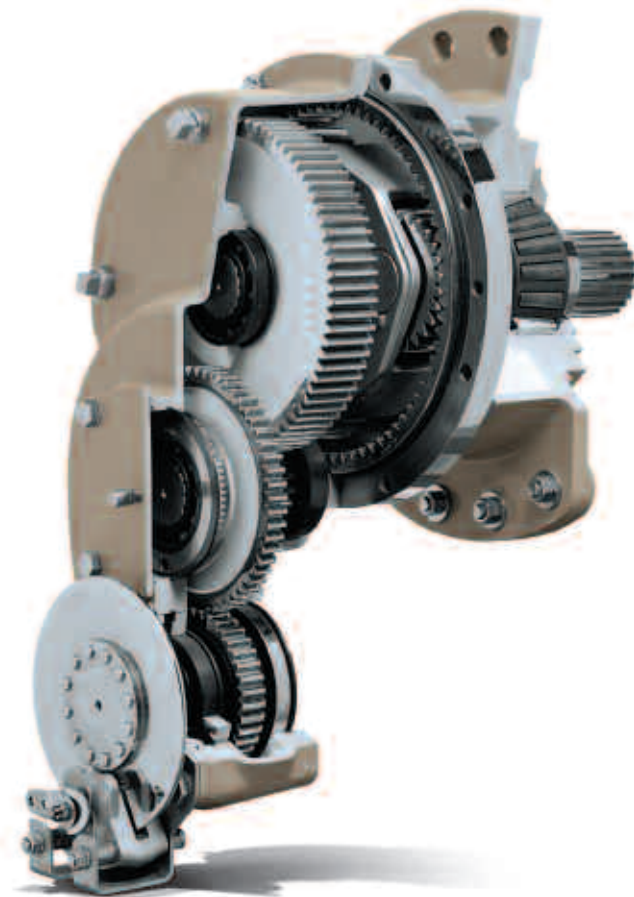

Planetary Drive Specifications

Drive type	Series model	Output torque, Nm (lb-ft)		Ratio range (5)	Input speed, max, rpm (1)	Maximum radial load, Kgf (lbs.) (2)	Maximum input power, kW (hp)	Approx. weight, kg (lbs.) (3)
		Intermittent	Continuous					
Speed reducer	F9R	12,880 (9,500) (4)	8,135 (6,000)	3.27–117:1	2800	14,287 (31,500)	27 (36)	100–181 (220–400)
	F12R	16,948 (12,500)	10,168 (7,500)	7.3–119:1	2800	14,287 (31,500)	35 (48)	91–122 (200–270)
	F25R	33,895 (25,000)	18,710 (13,800)	7.5–122:1	2800	28,570 (63,000)	71 (95)	215–263 (475–580)
	P25R	33,895 (25,000)	23,049 (17,000)	45–104:1	4000	–	97 (130)	143–178 (315–393)
	P40R	54,232 (40,000)	35,251 (26,000)	60–166:1	4000	–	123 (165)	322–413 (711–911)
	P65R	88,127 (65,000)	56,944 (42,000)	51–179:1	4000	–	138 (185)	392–455 (864–1004)
	P120R	162,696 (120,000)	88,127 (65,000)	64–194:1	4000	–	168 (225)	643–658 (1417–1450)
Swing	F12S	10,168 (7,500)	–	7.3–119:1	2800	20,862 (46,000)	35 (48)	104–136 (230–300)
	F25S	18,710 (13,800)	–	7.5–122:1	2800	28,570 (63,000)	71 (95)	286–322 (630–710)
	P25S	23,049 (17,000)	–	45–104:1	4000	13,605 (30,000)	97 (130)	211–246 (465–543)
	P40S	36,607 (27,000)	–	60–166:1	4000	36,281 (80,000)	123 (165)	514–605 (1133–1333)
	P65S	58,299 (43,000)	–	51–179:1	4000	40,816 (90,000)	138 (185)	656–720 (1447–1587)
	P120S	108,464 (80,000)	–	64–194:1	4000	68,027 (150,000)	168 (225)	915–942 (2017–2077)
	Track	P25T	33,895 (25,000)	23,049 (17,000)	45–104:1	4000	27,211 (60,000)	97 (130)
P40T		54,232 (40,000)	35,251 (26,000)	60–166:1	4000	36,281 (80,000)	123 (165)	455–518 (1003–1143)
P65T		88,127 (65,000)	56,944 (42,000)	51–179:1	4000	49,887 (110,000)	138 (185)	580–644 (1279–1419)
P120T		162,696 (120,000)	88,127 (65,000)	64–194:1	4000	104,308 (230,000)	168 (225)	912–927 (2011–2044)

(1) Maximum input speed related to ratio and maximum output speed.

(2) Maximum radial load placed at optimum load position.

(3) Weight varies with configuration and ratio selected.

(4) Requires tapered roller planet bearings (not available with all ratios).

(5) Actual ratio is dependent on the drive configuration.

Planetary Gear Drive Options

Choose from a wide selection of planetary gear drives to meet the needs of your design. Each series provides unique benefits that have been developed through years of design research and practical application.

Whether you need reducer drives, swing drives, or track drives, you can count on Funk planetary drives to deliver durability, performance, and superior engineering. Our drive designs include various ratios of input gear reduction sets, along with single and multiple combinations of center section planetary gears that drive

power through output arrangements to accommodate your reducer, swing, and track drive applications.

Our regional sales managers will assist you in analyzing our planetary drives and selecting the one that best fits the needs of your application.

NOTE: All data and specifications subject to change without notice or obligation. Application and installation are subject to review.

WARNING VEHICLE RUNAWAY HAZARD Avoid serious or fatal injury. This transmission is not a braking system. Install it only if there is a braking system capable of stopping vehicle with dead engine, disengaged transmission, or loss of hydrostatic retardation. Otherwise, vehicle may roll freely, resulting in loss of control.

F Series Input-Output Options

Model	Input Configurations	Center Section	Output Configurations	Output Shafts	Product Information																						
F12 and F25	<p>"O" SINGLE OFFSET (F12 AND F25 MODELS)</p> <p>"C" CENTER</p> <p>"L" LONG OFFSET</p> <p>"F" FLANGED</p>		<p>"P" PEDESTAL MOUNT</p> <p>"R" RADIAL MOUNT</p> <p>"S" SWING MOUNT</p>	<p>FLANGED</p> <p>KEYED</p> <p>SPLINED</p>	<p>F9 Model</p> <p>Output Rotation – same as input on all models</p> <p>Gear Ratios</p> <p>One Stage – 3.27:1, 4.89:1</p> <p>Two Stage – 10.7:1, 16.0:1, 23.9:1</p> <p>Three Stage – 35.0:1, 52.3:1, 78.2:1, 116.9:1</p> <p>Hydraulic Motor Mounting – SAE "B," "C," or "D" 2- or 4-bolt</p> <p>Input Spline – 13T, ¹⁶/₃₂P 14T, ¹²/₂₄P 13T, ⁸/₁₆P, 30° P.A.</p> <p>Output Shaft – splined – 23T, ⁸/₁₆P, 30° P.A.</p> <p>Output Shaft – keyed – 3" (Nom.) Dia. ⁵/₈" key width</p> <p>F12 Model</p> <p>O Input Configuration</p> <p>Output Rotation – opposite input</p> <p>Gear Ratios – 7.34:1, 10.76:1, 13.15:1, 24.14:1</p> <p>Hydraulic Motor Mounting – SAE "B" 2- or 4-bolt, or SAE "C" 4-bolt</p> <p>Input Spline – 13T, ¹⁶/₃₂P 14T, ¹²/₂₄P, 30° P.A.</p> <p>Output Shaft – splined – 29T, ⁸/₁₆P, 30° P.A.</p> <p>L and F Input Configurations</p> <p>Output Rotation – opposite input</p> <p>Gear Ratios – 19.73:1, 28.94:1, 36.22:1, 44.25:1, 53.12:1, 64.95:1, 81.22:1, 119.21</p> <p>Hydraulic Motor Mounting – SAE "B" or "C," 2- or 4-bolt</p> <p>Input Spline – 13T, ¹⁶/₃₂P 14T, ¹²/₂₄P, 30° P.A.</p> <p>Output Shaft – splined – 29T, ⁸/₁₆P, 30° P.A.</p> <p>F25 Model</p> <p>O Input Configurations</p> <p>Output Rotation – opposite input</p> <p>Gear Ratios – 7.50:1, 11.07:1, 13.75:1, 16.43:1, 20.00:1, 24.67:1</p> <p>Hydraulic Motor Mounting – SAE "C" or "D," 4-bolt</p> <p>Input Spline – 14T, ¹²/₂₄P 13T, ⁸/₁₆P, 30° P.A.</p> <p>Output Shaft – splined – 33T, ⁸/₁₆P, 30° P.A.</p> <p>Output Shaft – keyed – 4" (Nom.) Dia. 1" key width</p> <p>L and F Input Configurations</p> <p>Output Rotation – same as input</p> <p>Gear Ratios – 37.00:1, 54.61:1, 81.05:1, 121.67:1</p> <p>Hydraulic Motor Mounting – SAE "C" 2- or 4-bolt or SAE "D" 4-bolt</p> <p>Input Spline – 14T, ¹²/₂₄P 13T, ⁸/₁₆P, 30° P.A.</p> <p>Output Shaft – splined – 33T, ⁸/₁₆P, 30° P.A.</p> <p>Output Shaft – keyed – 4" (Nom.) Dia. 1" key width</p> <p>C Input Configuration</p> <p>Output Rotation – same as input</p> <p>Gear Ratios – 16.35:1, 24.45:1</p> <p>Hydraulic Motor Mounting – SAE "B," "C," or "D" 2- or 4-bolt</p> <p>Input Spline – 13T, ¹⁶/₃₂P 14T, ¹²/₂₄P 13T, ⁸/₁₆P, 30° P.A.</p> <p>Output Shaft – splined – 33T, ⁸/₁₆P, 30° P.A.</p> <p>Output Shaft – keyed – 4" (Nom.) Dia. 1" key width</p> <p>Lubrication</p> <p>Splash Lubrication</p> <p>Recommended Lubricant – EP Gear Oil meeting MIL-L-2105C or API Classification GL5</p>																						
	F9	<p>"C" CENTER</p> <p>"F" FLANGED</p>		<p>"P" PEDESTAL MOUNT</p> <p>"R" RADIAL MOUNT</p> <p>"S" SWING MOUNT</p>	<p>FLANGED</p> <p>KEYED</p> <p>SPLINED</p>																						
<p>Model Outputs Inputs</p> <p style="text-align: center;">Dimensions — Millimeters (Inches)</p>																											
F9	R	C	A Standard	B* Optional	C	D	E	F	G	<p>* NOTE: Optional input pads may alter dimensions shown. Two-bolt SAE mounting pads available on some styles. ** One pad blocked on "O" single offset input configuration. *** Not available on F12 models.</p>																	
			SAE "C" 1/2" - 13 UNC 4 PLCS. ON 162 (6.375) B.C.D.	SAE "D" 3/4" - 10 UNC 4 PLCS. ON 228.6 (9.000) B.C.D.	356 (14.0)	95.3 (3.75)	One Stage W/SAE "D" PAD 378 (14.88) W/SAE "C" PAD 387 (15.25)	Two Stage W/SAE "D" PAD 460 (18.13) W/SAE "C" PAD 470 (18.5)	Three Stage W/SAE "D" PAD 543 (21.38) W/SAE "C" PAD 552 (21.75)	H	I	J	K	L	M	N	O	P	Q	R	S	T	U	V	W	X	Y
F12	R, S	F, L, O	SAE "C" 1/2" - 13 UNC 4 PLCS. ON 162 (6.375) B.C.D.	SAE "B" 1/2" - 13 UNC 4 PLCS. ON 127 (5.000) B.C.D.	—	181 (7.13)	76 (3.00)	305 (12.0)	368 (14.5)	152 (6.0)	151 (5.94)	12.7 (0.5)	356 (14.0)	356 (14.0)	81 (3.18)	191 (7.5)	182 (7.18)	—	—	132 (5.18)	235 (9.25)	432 (17.0)	95.3 (3.75)	—	37.8 (1.5)	159 (6.25)	20 Dia. (.78) 10 holes on 222 (8.75) B.C.D.
F25	P, R, S	C, D, F L, O	SAE "C" 1/2" - 13 UNC 4 PLCS. ON 162 (6.375) B.C.D.	SAE "D" 3/4" - 10 UNC 4 PLCS. ON 228.6 (9.000) B.C.D.	Two Stage 168 (6.63) Three Stage 237 (9.31)	204 (8.02)	90 (3.53)	381 (15.0)	508 (20.0)	191 (7.5)	154 (6.06)	45 (1.77)	479 (18.88)	502 (19.75)	102 (4.0)	254 (10.0)	229 (9.0)	260 (10.25)	562 (22.12)	168 (6.63)	267 (10.5)	657 (25.88)	95.3 (3.75)	101.55/101.52 (3.998/3.997)	37.8 (1.5)	270 (10.62)	26.2 Dia. (1.03) 10 holes on 335 (13.188) B.C.D.

P Series Input-Output Options

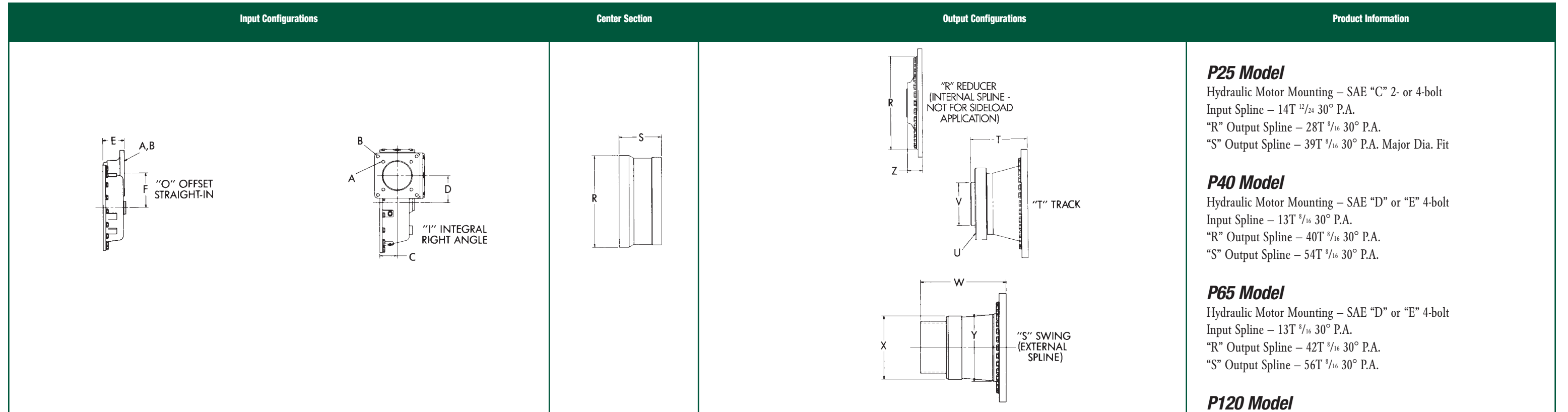

Model	Outputs	Inputs	Dimensions — Millimeters (Inches) * May vary with some ratios														
			A	B	C	D	E	F	R	S*	T	U	V	W	X	Y	Z
P25	R, S, T	I, O	SAE "C" 1/2 - 13 UNC 4 PLCS. ON 162 (6.375) B.C.D.	SAE "C" 5/8 - 11 UNC 4 PLCS. ON 181 (7.125) B.C.D.	87.5 (3.45)	91.2 (3.59)	140 (5.50)	107.7 (4.24)	339.7 (13.375)	190.5 (7.50)	283 (9.38)	5/8 - 18 UNF 24 PLCS. ON 260 (10.25) B.C.D.	216 (8.50)	267 (10.50)	279.4 (11.00)	339.7 (13.375)	73.2 (2.88)
P40	R, S, T	D, I, O	SAE "D" 3/4 - 10 UNC 4 PLCS. ON 228.6 (9.00) B.C.D.	SAE "E" 3/4 - 10 UNC 4 PLCS. ON 317.5 (12.50) B.C.D.	108 (4.25)	142 (5.59)	124 (4.88)	142 (5.59)	521 (20.50)	215.4 (8.48)	278 (10.94)	3/4 - 10 UNC 24 PLCS. ON 317.5 (12.50) B.C.D.	267 (10.50)	468.4 (18.44)	355.6 (14.00)	393.7 (15.50)	91.9 (3.62)
P65	R, S, T	C, I, O	SAE "D" 3/4 - 10 UNC 4 PLCS. ON 228.6 (9.00) B.C.D.	SAE "E" 3/4 - 10 UNC 4 PLCS. ON 317.5 (12.50) B.C.D.	108 (4.25)	142 (5.59)	124 (4.88)	142 (5.59)	Center 533.4 (21.00) "R" 546.1 (21.50)	244.6 (9.63)	333.5 (13.13)	1 1/4 - 7 UNC 18 PLCS. ON 350 (13.779) B.C.D.	250 (9.85)	526 (20.72)	368 (14.50)	393.7 (15.50)	93 (3.66)
P120	R, S, T	I, K, O	SAE "D" 3/4 - 10 UNC 4 PLCS. ON 228.6 (9.00) B.C.D.	SAE "E" 3/4 - 10 UNC 4 PLCS. ON 317.5 (12.50) B.C.D.	102 (4.00)	"J" 156.5 (6.16) "K" 184.2 (7.25)	232 (9.13)	156.5 (6.16)	590.6 (23.25)	279.4 (11.00)	424 (16.7)	7/8 - 9 UNC 32 PLCS. ON 495 (19.50) B.C.D.	431.8 (17.00)	574.5 (22.62)	381 (15.00)	406.4 (16.00)	140 (5.50)

P25 Model
 Hydraulic Motor Mounting – SAE "C" 2- or 4-bolt
 Input Spline – 14T ¹²/₂₄ 30° P.A.
 "R" Output Spline – 28T ⁸/₁₆ 30° P.A.
 "S" Output Spline – 39T ⁸/₁₆ 30° P.A. Major Dia. Fit

P40 Model
 Hydraulic Motor Mounting – SAE "D" or "E" 4-bolt
 Input Spline – 13T ⁸/₁₆ 30° P.A.
 "R" Output Spline – 40T ⁸/₁₆ 30° P.A.
 "S" Output Spline – 54T ⁸/₁₆ 30° P.A.

P65 Model
 Hydraulic Motor Mounting – SAE "D" or "E" 4-bolt
 Input Spline – 13T ⁸/₁₆ 30° P.A.
 "R" Output Spline – 42T ⁸/₁₆ 30° P.A.
 "S" Output Spline – 56T ⁸/₁₆ 30° P.A.

P120 Model
 Hydraulic Motor Mounting – SAE "D" or "E" 4-bolt
 Input Spline – 13T ⁸/₁₆ 30° P.A.
 "R" Output Spline – 48T ⁸/₁₆ 30° P.A.
 "S" Output Spline – 60T ⁸/₁₆ 30° P.A.

All P Series Models
Rotation
 Output Rotation – same as input on I input configurations
 Output Rotation – opposite input on O input configurations
Gear Ratios
 Consult your nearest Funk drivetrain component dealer for available ratios.
Lubrication
 Splash Lubrication
 Recommended lubricant – EP Gear Oil
 meeting MIL-L-2105C or API Classification GL5