



KOHLER®

KSD Series

| Diesel Engines

18.4 kW | 24.7 hp

Simple, advanced, versatile.
Experience the next level of engine technology,
compatible with all kinds of non-road machines,
compliant with all global exhaust emissions norms.

Innovations and benefits

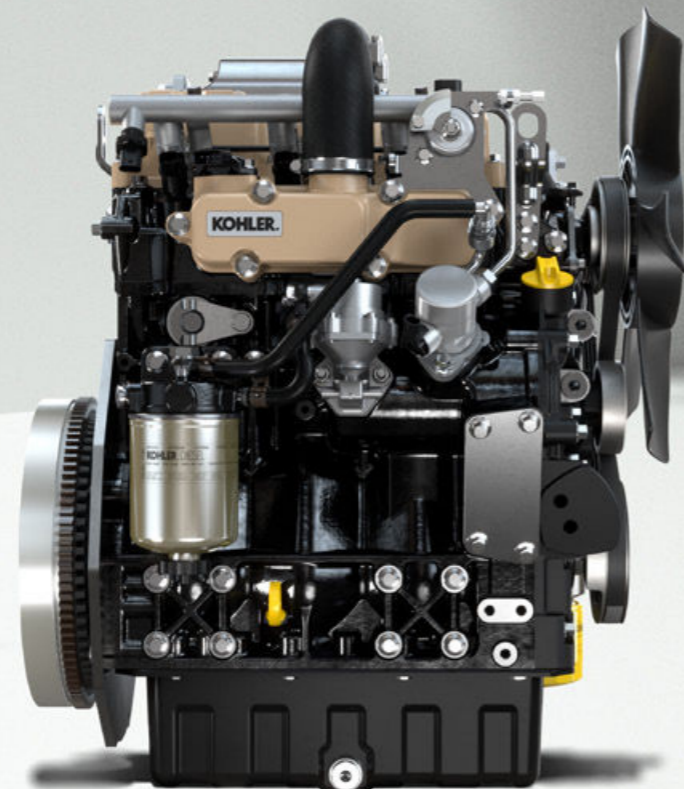

EMISSIONS STANDARDS

The wide variety of emission standards has introduced a new level of complexity to the engines business. The KOHLER KSD is a new base engine below 19 kW that complies with all global emissions standards and fuels.

ELECTRONIC CONTROL

The versatility of KOHLER KSD engines goes beyond performance, with the ability to easily fit into existing machine platforms. KOHLER KSD engines are electronically managed, while being as simple to use as mechanical engines. The fuel system allows precise fuel metering and excellent load response, resulting in increased productivity. Moreover, KSD engines offer switchability for gensets.

COMBUSTION SYSTEM

The innovative technology brought on by the KOHLER KSD is its architecture: it features a state-of-the-art indirect injection system but has the electronic management typical of direct injection engines.

- The engine performance is maximized in every operating condition and environment
- Outstanding engine response
- The remarkable low-end torque values allow the operator to run their piece of equipment at lower rpm to save fuel
- The electronic injection system results in no visible black smoke
- Noise and vibrations are minimized

EASE OF INSTALLATION

KOHLER KSD engines do not require any kind of machine re-designing from OEMs.

As a result, KOHLER KSD engines offer a drop-in solution for existing applications.

SERVICE & TOTAL COST OF OWNERSHIP

KOHLER KSD engines allow for prognostic, diagnostic, geolocation, and remote monitoring to minimize machine downtime.

KOHLER KSD engines offer 2,000 hours of service interval of the Poly-V fan belt and no valve lash adjustment. The service interval of up to 500 hours for both oil and fuel filters and a 3-year warranty providing up to 2000 hours of protection reduces the total cost of ownership, making KSD-powered applications extremely productive with increased uptime.

The indirect injection system does not affect the fuel consumption rate: on the contrary, the electronic management and the focus on clean combustion drive low oil and fuel consumption and avoid oil dilution as well as heavy soot oil contamination.



ELECTRONIC FUEL INJECTION

SAVES TIME AND INCREASES PRODUCTIVITY

DURABLE COMPONENTS



SIMPLE, ADVANCED, VERSATILE

EASY-TO-INTEGRATE SOLUTIONS

COMPATIBLE WITH ALL KINDS OF MACHINES



COMPLIANT WITH ALL EMISSIONS STANDARDS WORLDWIDE

Turbo Common Rail Engines

Standard equipment

INTAKE MANIFOLD

EXHAUST MANIFOLD

TOP & SIDE OIL REFILLING

ELECTRIC STARTER

45A ALTERNATOR

BACKPLATE FLANGE

DROP-IN FLYWHEEL

OIL FILTER ENGINE MOUNTED
+ OIL COOLER

FUEL FILTER ENGINE MOUNTED

ECU

OIL SUMP CAPACITY 3.7 L

BASIC J1939 ENABLED WIRING
HARNESS

Accessories on demand

FLYWHEEL HOUSING:

- SAE 4
- SAE 5

FLYWHEEL:

- INTL. STD. SAE (7 $\frac{1}{2}$ ")
- INTL. STD. SAE (6 $\frac{1}{2}$ ")

HYDRAULIC PUMP PROVISION
ON 3RD PTO

FLEXIBLE FAN POSITION

HIGH CAPACITY
OIL SUMP 5.3 L

REMOTE OIL AND FUEL FILTER

80A ALTERNATOR
FULL CAPACITY WIRING
HARNESS

MUFFLER

RADIATOR

HEAVY DUTY AIR CLEANER

ARCTIC BOOST
($\leq -26^{\circ}\text{C}$ STARTABILITY)



KSD 1403TCA

Turbo Common Rail with Aftercooler

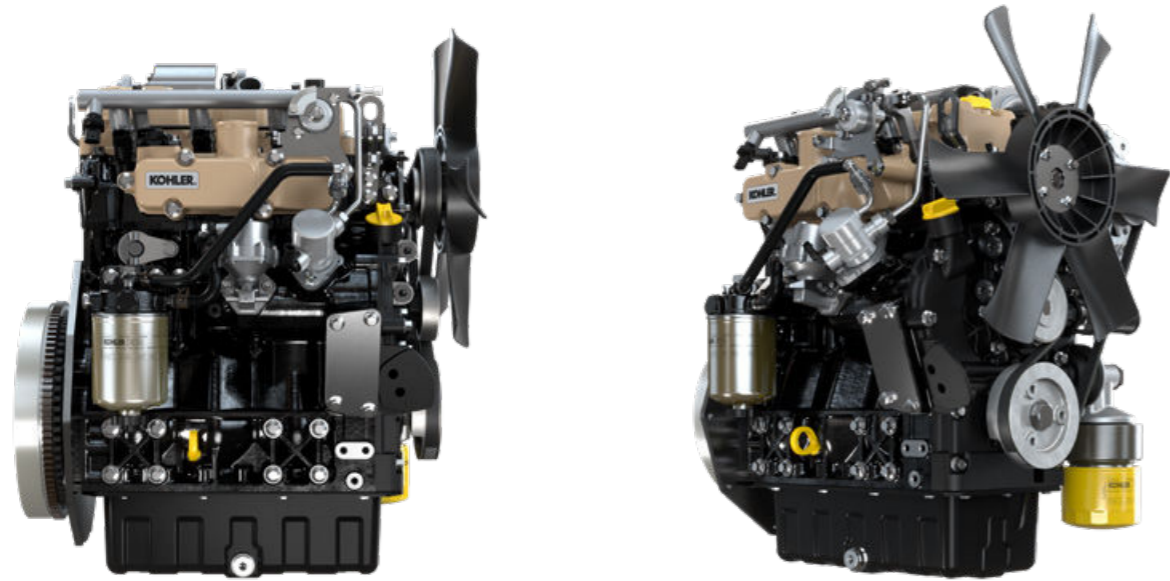

Data

Dimensions (mm)

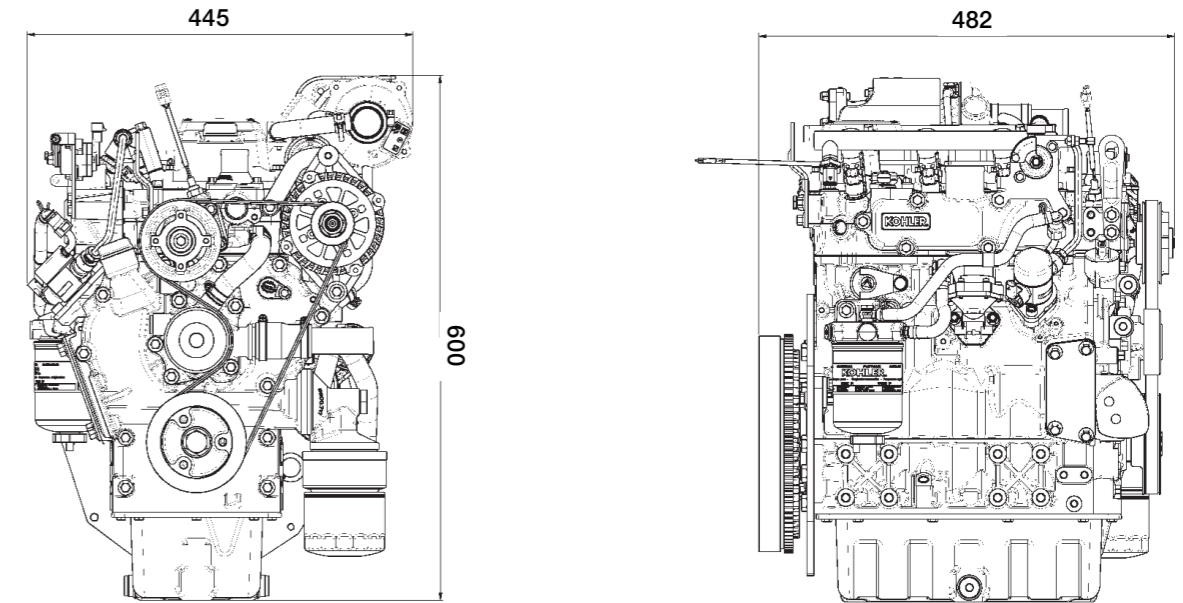

QUICK SPECIFICATIONS	KSD 1403TCA
CYLINDERS / FIE	3 / TURBO COMMON RAIL
MAX POWER kW (HP) @ rpm	18.4 (24.7) @ 3000 US TIER 4 FINAL 18.9 (25.7) @ 3000 STAGE V*
MAX TORQUE Nm @ rpm	120 @ 1400
EMISSION COMPLIANCE	US TIER 4 FINAL / EU STAGE V



*Engine model with double emission compliance (Stage V/Tier 4 Final): 18.4 kW (24.7 hp) @ 3000 rpm

Performance curves

(ACCORDING TO ISO 14396)

KSD 1403TCA - TURBO COMMON RAIL WITH AFTERCOOLER

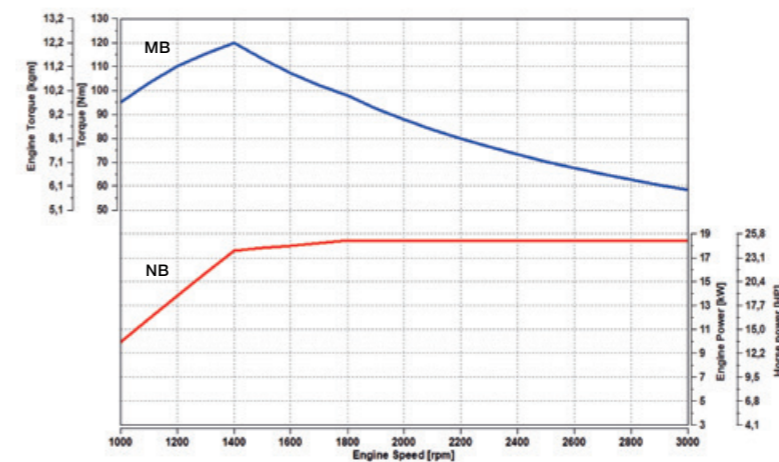

— MB – Torque curve
— NB – Power curve

Performances measured according to ISO 14396 without final intake and exhaust line. Actual engine performances may be affected by accessories (intake and exhaust line, charging, cooling fan, etc.), application, ambient operating conditions (temperature, humidity, and altitude) and other factors.

KSD 1403TC

Turbo Common Rail

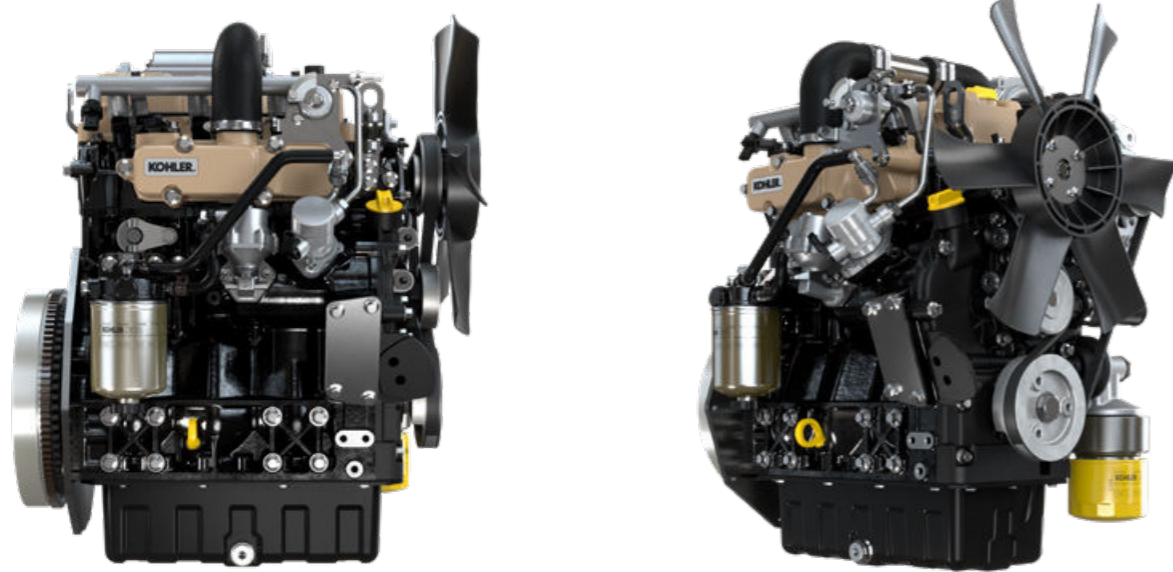

Data

Dimensions (mm)

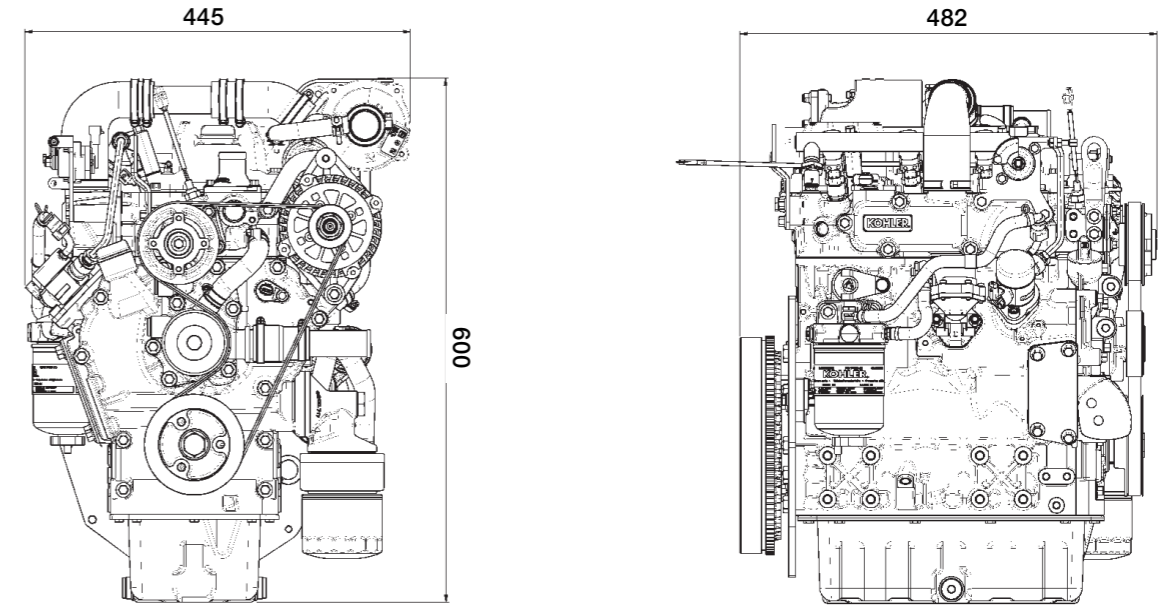

QUICK SPECIFICATIONS	KSD 1403TC
CYLINDERS / FIE	3 / TURBO COMMON RAIL
MAX POWER kW (HP) @ rpm	18.4 (24.7) @ 3000 US TIER 4 FINAL 18.9 (25.7) @ 3000 STAGE V*
MAX TORQUE Nm @ rpm	105 @ 1500
EMISSION COMPLIANCE	US TIER 4 FINAL / EU STAGE V



*Engine model with double emission compliance (Stage V/Tier 4 Final): 18.4 kW (24.7 hp) @ 3000 rpm

Performance curves

(ACCORDING TO ISO 14396)

KSD 1403TC - TURBO COMMON RAIL

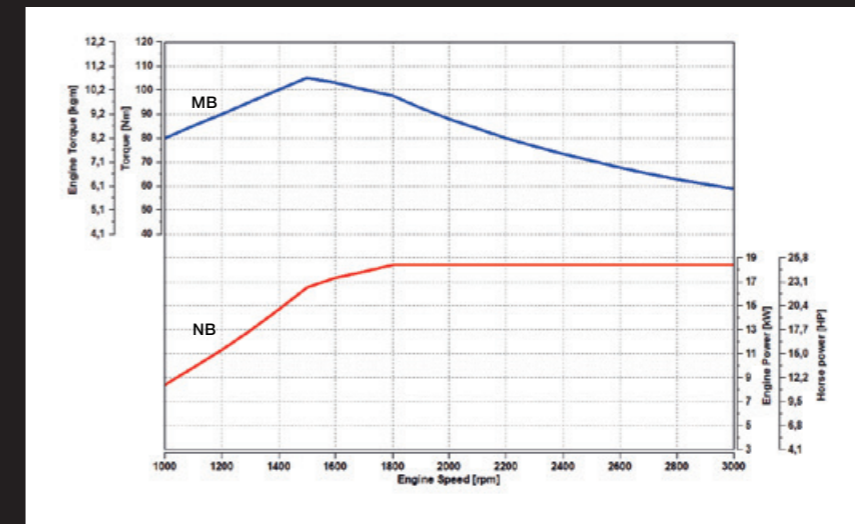

— MB – Torque curve
— NB – Power curve

Performances measured according to ISO 14396 without final intake and exhaust line. Actual engine performances may be affected by accessories (intake and exhaust line, charging, cooling fan, etc.), application, ambient operating conditions (temperature, humidity, and altitude) and other factors.

Naturally Aspirated Engines

Standard equipment

INTAKE MANIFOLD

EXHAUST MANIFOLD

TOP & SIDE OIL REFILLING

ELECTRIC STARTER

45A ALTERNATOR

BACKPLATE FLANGE

DROP-IN FLYWHEEL

OIL FILTER ENGINE MOUNTED

FUEL FILTER ENGINE MOUNTED

ECU

OIL SUMP CAPACITY 3.7 L

BASIC J1939 ENABLED WIRING HARNESS

Accessories on demand

FLYWHEEL HOUSING:

- SAE 4
- SAE 5

FLYWHEEL:

- INTL. STD. SAE (7 1/2")
- INTL. STD. SAE (6 1/2")

HYDRAULIC PUMP PROVISION ON 3RD PTO

FLEXIBLE FAN POSITION

HIGH CAPACITY OIL SUMP 5.3 L

REMOTE OIL AND FUEL FILTER

80A ALTERNATOR
FULL CAPACITY WIRING HARNESS

MUFFLER

RADIATOR

HEAVY DUTY AIR CLEANER

ARCTIC BOOST (≤-26°C STARTABILITY)



KSD 1403NA

Naturally Aspirated

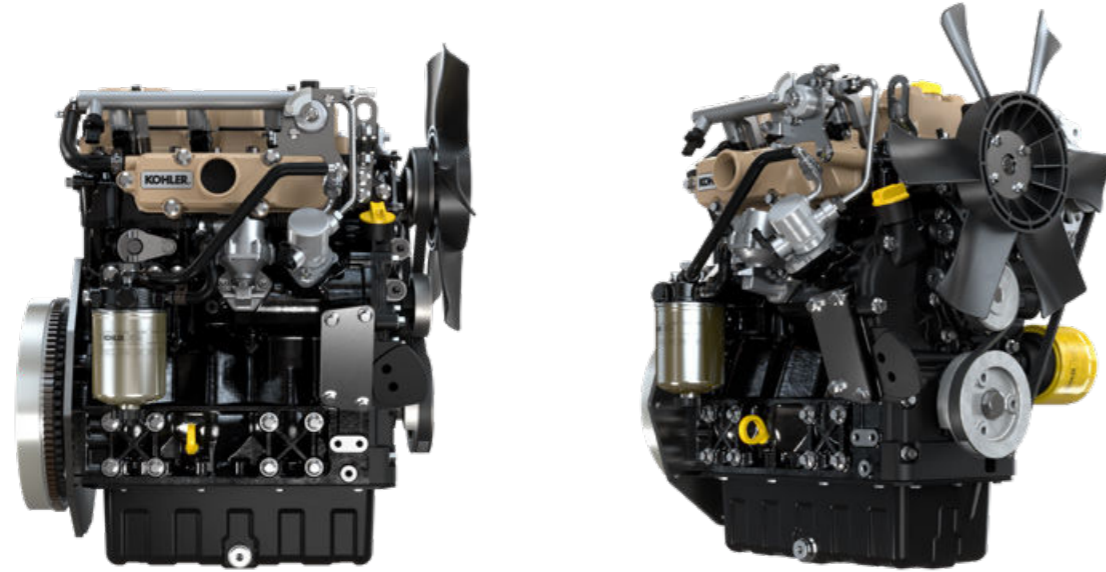

Data

Dimensions (mm)

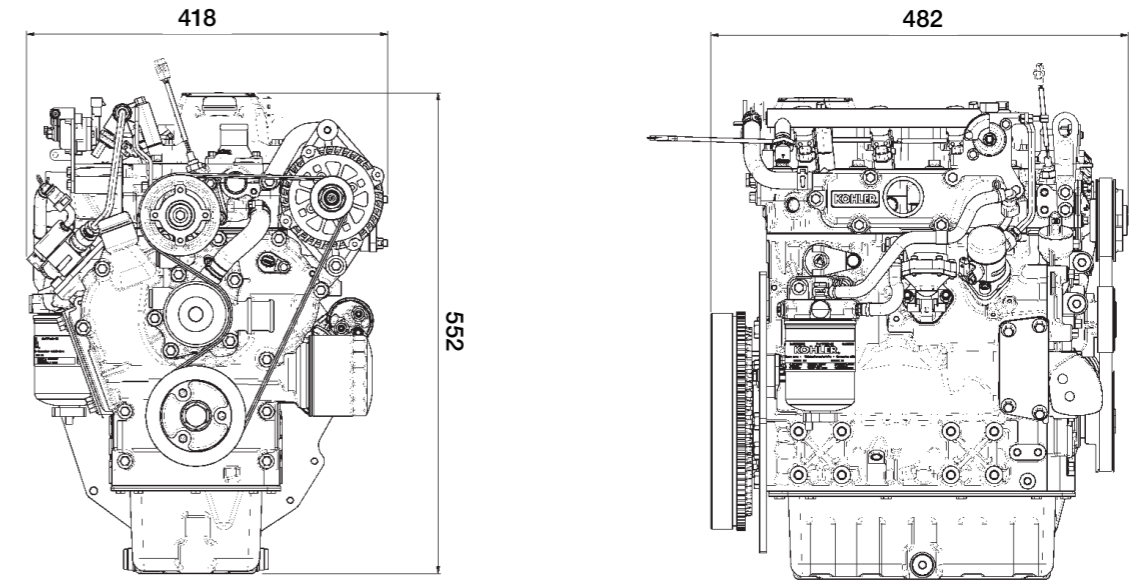

QUICK SPECIFICATIONS	KSD 1403NA
CYLINDERS / FIE	3 / COMMON RAIL
MAX POWER kW (HP) @ rpm	18.4 (24.7) @ 3000 US TIER 4 FINAL 18.9 (25.7) @ 3000 STAGE V*
MAX TORQUE Nm @ rpm	90 @ 1800
EMISSION COMPLIANCE	US TIER 4 FINAL / EU STAGE V



*Engine model with double emission compliance (Stage V/Tier 4 Final): 18.4 kW (24.7 hp) @ 3000 rpm

Performance curves

(ACCORDING TO ISO 14396)

KSD 1403NA - NATURALLY ASPIRATED

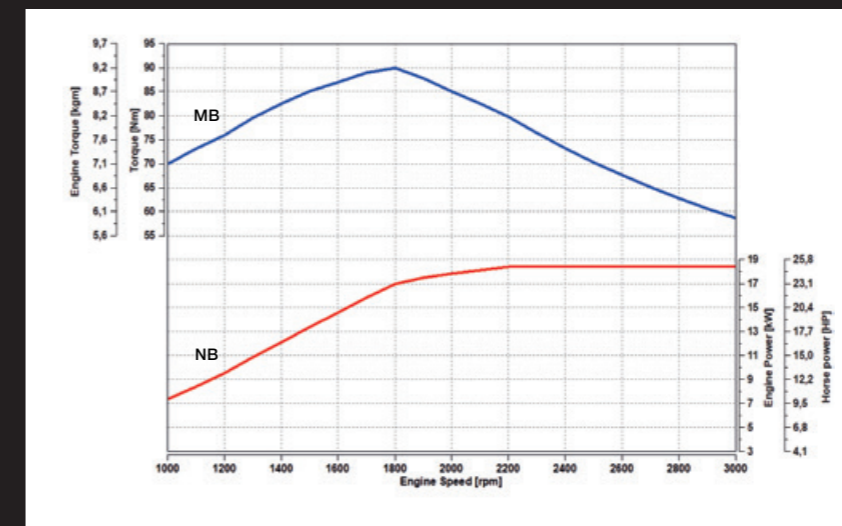

— MB – Torque curve
— NB – Power curve

Performances measured according to ISO 14396 without final intake and exhaust line. Actual engine performances may be affected by accessories (intake and exhaust line, charging, cooling fan, etc.), application, ambient operating conditions (temperature, humidity, and altitude) and other factors.

Turbo Common Rail Engines



MODEL		KSD 1403TCA	KSD 1403TC
ENGINE SPECS	4 STROKE DIESEL WITH CYLINDER IN LINE	.	.
	LIQUID COOLING	.	.
	2 VALVES PER CYLINDER	.	.
	IN CRANKCASE CAMSHAFT, GEAR TRAIN DRIVEN	.	.
	PUSHROD - ROCKER ARMS TIMING WITH HYDRAULIC TAPPETS	.	.
	CAST IRON CRANKCASE	.	.
	CAST IRON CYLINDER HEAD	.	.
	CLOSED CRANKCASE VENTILATION SYSTEM	.	.
TECHNICAL FEATURES	CYLINDER	3	3
	BORE (mm)	81	81
	STROKE (mm)	90	90
	ENGINE DISPL (cm³)	1391	1391
	INJECTION SYSTEM	IDI	IDI
	INJECTION EQUIPMENT	IDI COMMON RAIL	IDI COMMON RAIL
	AFTERCOOLER	.	-
PERFORMANCE	MAX POWER (ISO 14396) [kW(hp) @ rpm]	18.4 (24.7) @ 3000 US TIER 4 F 18.9 (25.7) @ 3000 STAGE V¹	18.4 (24.7) @ 3000 US TIER 4 F 18.9 (25.7) @ 3000 STAGE V¹
	MAX TORQUE (ISO 14396) (Nm @ rpm)	120 @ 1400	105 @ 1500
	LOW-END TORQUE (Nm @ 1000 rpm)	95	80
	EMISSION COMPLIANCE	EU STAGE V US TIER 4 FINAL	EU STAGE V US TIER 4 FINAL
FUEL ECONOMY	BEST POINT (G/kWh)	242	245
	MAX POWER (G/kWh @ 1800 rpm)	255	256
STARTABILITY	UNAIDED (°C)	DOWN TO -15	DOWN TO -15
	UNAIDED (°C) WITH ARCTIC BOOST	DOWN TO -26	DOWN TO -26
	AIDED (°C) [COOLANT HEATER]	BELOW -26	BELOW -26
FUEL COMPATIBILITY	EN 590	.	.
	NO 1 DIESEL (US) - ASTM D 975-09 B - GRADE 1-D S 15	.	.
	NO 2 DIESEL (US) - ASTM D 975-09 B - GRADE 2-D S 15	.	.
	ARCTIC EN 590/ASTM D 975-09 B (NO PETROLEUM ADDED)	.	.
	HIGH SULFUR FUEL < 2000 PPM *	.	.
	HVO - HYDROTREATED VEGETABLE OIL	.	.
SERVICE FEATURES	OIL/FILTER CHANGE INTERVAL STD/ SYNTHETIC (HR)	500-1000**	500-1000**
	ALTERNATOR BELT REPLACEMENT	36 MTH	36 MTH
	COOLANT CHANGE	24 MTH	24 MTH
	OIL CONSUMPTION (% FUEL)	<0.05	<0.05
	H x L x W (FAN EXCLUDED) (mm)	600 X 482 X 445	600 X 482 X 445
PHYSICAL CHARACTERISTICS	WEIGHT (kg)	126	127
	DAILY SERVICE POINTS - POSITIONS	OPTIONAL SINGLE SERVICE SIDE (SELECT SIDE)	OPTIONAL SINGLE SERVICE SIDE (SELECT SIDE)
	AMBIENT OPERATING TEMPS (°C)	-40 TO +50***	-40 TO +50***
	GRADEABILITY-ALL ROUND (CONTINUOUS) (Deg)	35	35
	GRADEABILITY-ALL ROUND (INTERMITTENT-1MIN) (Deg)	45	45
	LUBRICATION	OIL TYPE	10W-40 API CI4
AUXILIARY PTOS (3 RD OPTIONAL)	MAX TORQUE (Nm)	40	40
	DRIVE RATIO	1:1 TIMES ENGINE SPEED	1:1 TIMES ENGINE SPEED
	PROVISION FOR A DOUBLE GR.2 TANDEM HYDRAULIC PUMP	.	.

* With restrictions ** According to operating conditions ***Case by case evaluation for special application requirements.
¹ Engine model with double emission compliance (Stage V/Tier 4 Final): 18.4 kW (24.7 hp) @ 3000 rpm

Naturally Aspirated Engines



MODEL		KSD 1403NA
ENGINE SPECS	4 STROKE DIESEL WITH CYLINDER IN LINE	.
	LIQUID COOLING	.
	2 VALVES PER CYLINDER	.
	IN CRANKCASE CAMSHAFT, GEAR TRAIN DRIVEN	.
	PUSHROD - ROCKER ARMS TIMING WITH HYDRAULIC TAPPETS	.
	CAST IRON CRANKCASE	.
	CAST IRON CYLINDER HEAD	.
	CLOSED CRANKCASE VENTILATION SYSTEM	.
TECHNICAL FEATURES	CYLINDER	3
	BORE (mm)	81
	STROKE (mm)	90
	ENGINE DISPL (cm³)	1391
	INJECTION SYSTEM	IDI
	INJECTION EQUIPMENT	IDI COMMON RAIL
	AFTERCOOLER	-
PERFORMANCE	MAX POWER (ISO 14396) [kW(hp) @ rpm]	18.4 (24.7) @ 3000 US TIER 4 FINAL 18.9 (25.7) @ 3000 STAGE V¹
	MAX TORQUE (ISO 14396) (Nm @ rpm)	90 @ 1800
	LOW-END TORQUE (NM @ 1000 rpm)	70
	EMISSION COMPLIANCE	EU STAGE V US TIER 4 FINAL
FUEL ECONOMY	BEST POINT (G/kWh)	243
	MAX POWER (G/kWh @ 2200 rpm)	253
STARTABILITY	UNAIDED (°C)	DOWN TO -15
	UNAIDED (°C) WITH ARCTIC BOOST	DOWN TO -26
	AIDED (°C) [COOLANT HEATER]	BELOW -26
FUEL COMPATIBILITY	EN 590	.
	NO 1 DIESEL (US) - ASTM D 975-09 B - GRADE 1-D S 15	.
	NO 2 DIESEL (US) - ASTM D 975-09 B - GRADE 2-D S 15	.
	ARCTIC EN 590/ASTM D 975-09 B (NO PETROLEUM ADDED)	.
	HIGH SULFUR FUEL < 2000 PPM *	.
	HVO - HYDROTREATED VEGETABLE OIL	.
SERVICE FEATURES	OIL/FILTER CHANGE INTERVAL STD/ SYNTHETIC (HR)	500-1000**
	ALTERNATOR BELT REPLACEMENT	36 MTH
	COOLANT CHANGE	24 MTH
	OIL CONSUMPTION (% FUEL)	<0.05
	H x L x W (FAN EXCLUDED) (mm)	552 X 482 X 418
PHYSICAL CHARACTERISTICS	WEIGHT (kg)	121
	DAILY SERVICE POINTS - POSITIONS	OPTIONAL SINGLE SERVICE SIDE (SELECT SIDE)
	AMBIENT OPERATING TEMPS (°C)	-40 TO +50***
	GRADEABILITY-ALL ROUND (CONTINUOUS) (Deg)	35
	GRADEABILITY-ALL ROUND (INTERMITTENT-1MIN) (Deg)	45
	LUBRICATION	OIL TYPE
AUXILIARY PTOS (3 RD OPTIONAL)	MAX TORQUE (Nm)	40
	DRIVE RATIO	1:1 TIMES ENGINE SPEED
	PROVISION FOR A DOUBLE GR.2 TANDEM HYDRAULIC PUMP	.

For more information, contact your KOHLER source of supply.
Kohler Co. reserves the right to make modifications without prior notice.

KOHLER®